

SIDDHARTH GROUP OF INSTITUTIONS :: PUTTUR

Siddharth Nagar, Narayanavanam Road – 517583

QUESTION BANK (DESCRIPTIVE)
Subject with Code : Strength of Materials – I (19CE0102)

Course & Branch: B.Tech - CE

Year & Sem: I-B.Tech & II-Sem

Regulation: R19

UNIT – I
SIMPLE STRESSES AND STRAINS & COMPOUND STRESSES AND STRAINS

- (a) Draw Stress – Strain for mild steel bar subjected to tensile loading and mark salient points on the graph.
 (b) A hollow cast iron cylinder 4 m long, 300 mm outer diameter, and thickness of metal 50 mm is subjected to a central load on the top when standing straight. The stress produced is $75 \times 10^3 \text{ kN/m}^2$. Assume Young's Modulus for cast iron as $1.5 \times 10^8 \text{ kN/m}^2$ and find (i) magnitude of load (ii) longitudinal strain produced, and (iii) total decrease in length.
- A specimen of steel 25 mm in diameter with a gauge length of 200 mm is tested to destruction. It has an extension of 0.16 mm under a load of 80 kN and the load at elastic limit is 160 kN. The maximum load is 180 kN. The total extension is 56 mm and diameter at the neck is 18 mm. Find (i) The stress at elastic limit (ii) Young's modulus (iii) Percentage of elongation (iv) percentage reduction in area (v) Ultimate tensile stress.
- (a) A prismatic member of length l is having a uniform cross-sectional area A is subjected to a load P along the longitudinal axis. What will be the change in length δl due to application of load P .
 (b) A steel bar of 25 mm diameter is acted upon by force as shown in figure below. What is the total elongation of the bar, if $E = 190 \text{ GPa}$?

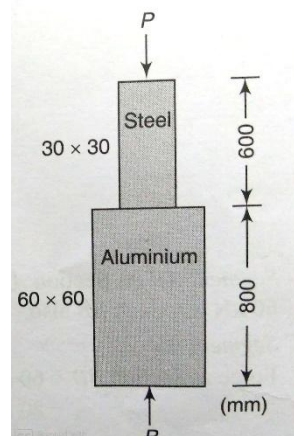

4. A bar of 20 mm diameter is tested in tension. It is observed that when a load of 37.7 kN is applied, the extension measured over a gauge length of 200 mm is 0.12 mm and contraction in diameter is 0.0036 mm. find the Poisson's ratio, Yong's modulus, bulk modulus of elasticity and modulus of rigidity.

5. A uniformly tapered circular bar of length l is having a diameter of d_1 at one end and the diameter is reduced to d_2 at the other end. If this bar is subjected to a tensile load of magnitude P , find the equation for the change in the length of the bar δl .

6. Three pillars, two of aluminium and one of steel, support a rigid plat form of 20 kN as shown in the figure. If the area of each aluminium pillar is 1000 mm^2 and that of steel pillar is 800 mm^2 , find the stress developed in each pillar. Take $E_a = 1 \times 10^5 \text{ N/mm}^2$ and $E_s = 2 \times 10^5 \text{ N/mm}^2$. What additional load P can it take if working stresses are 65 N/mm^2 in aluminium and 150 N/mm^2 in steel?

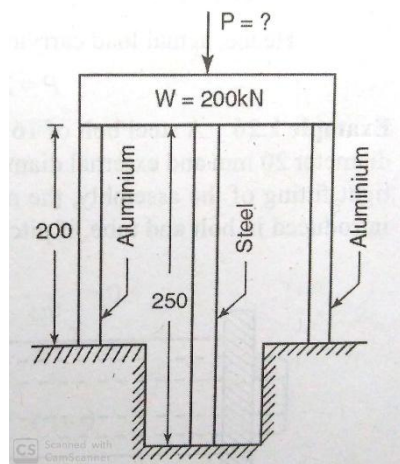

7. A steel rail is 12.6 m long and is laid at a temperature of 24°C . The maximum temperature expected is 44°C .

(i) Estimate the minimum gap to be left between two rails so that temperature stresses do not develop

(ii) Calculate the thermal stresses developed in the rails if

(a) No expansion joint is provided

(b) If a 2 mm gap is provided for expansion

(iii) If the stress developed is 20 MN/m^2 , What is the gap between the rails?

Take $E = 2 \times 10^5 \text{ MN/m}^2$ and $\alpha = 12 \times 10^{-6} / ^\circ\text{C}$.

8. A rectangular bar 500 mm long and 100 mm x 50 mm in cross-section is subjected to forces as shown in the figure. What is the change in the volume of the bar? Take modulus of elasticity for the bar material as 200 GPa and Poisson's ratio as 0.25.

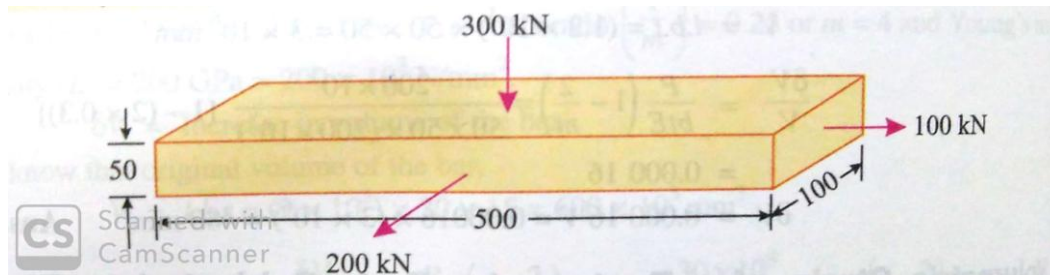

9. Obtain an expression for the major and minor principal stresses on a plane, when the body is subjected to direct stresses in two mutually perpendicular directions accompanied by a shear stress.

10. A point in a strained material is subjected to the stresses as shown in figure. Find graphically the normal and shear stresses on the section AB.

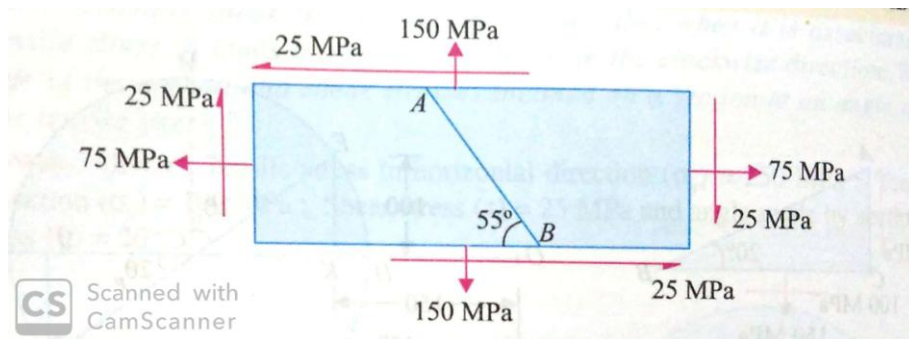

UNIT – II

SHEAR FORCE AND BENDING MOMENTS

- Draw the shear force and bending moment diagrams in the following cases of cantilevers:
 - Span of 10 m with udl of 3 kN/m for 6 m starting from the free end
 - Span of 10 m with udl of 3 kN/m for 6 m starting from the fixed end
 - Span of 14 m with udl of 3 kN/m for 6 m starting from 4 m and ending at 10 m from the fixed end
- A cantilever of 14 m span carries loads of 6 kN, 4 kN, 6 kN and 4 kN at 2 m, 4 m, 7 m and 14 m respectively from the fixed end. If also has a uniformly distributed load of 2 kN/m run for the length between 4 m and 10 m from the fixed end. Draw the shear force and bending moment diagrams.
- A cantilever beam of 2 m span is subjected to a gradually varying load from 2 kN/m to 5 kN/m as shown in figure. Draw the shear force and bending moment diagrams for the beam.

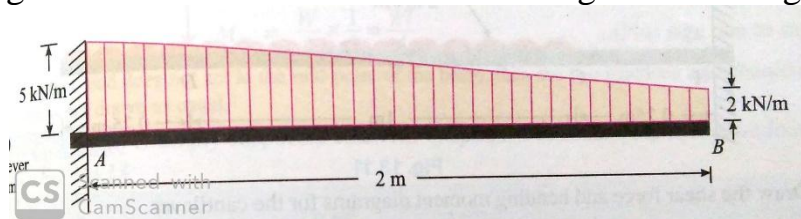

- A 10 m long simply supported beam carries two points loads of 10 kN and 6 kN at 2 m and 9 m respectively from the left end. It has also a uniformly distributed load of 4 kN/m run for the length between 4 m and 7 m from the left end. Draw shear force and bending moment diagrams.
- Draw shear force and bending moment diagrams for the beam shown in figure. Indicate the numerical values at all important sections. Also determine the point of contraflexure.

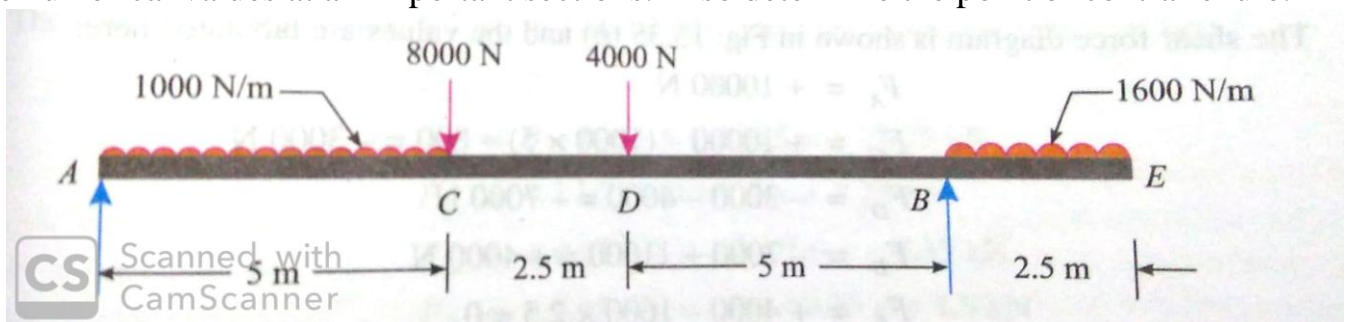

- A simply supported beam with over-hanging ends carries transverse loads as shown in figure. If $W = 10.w$, what is the overhanging length on each side, such that the bending moment at the middle of the beam, is zero? Sketch the shear force and bending moment diagrams.

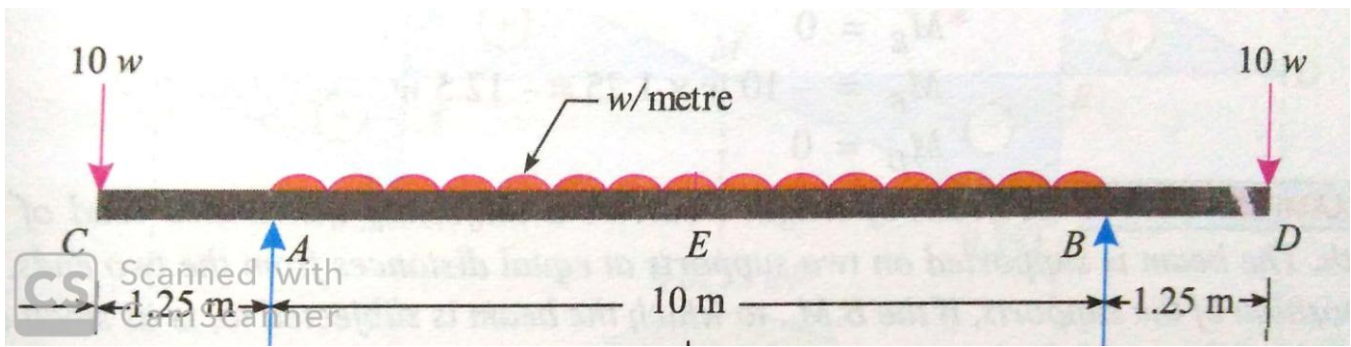

7. A simply supported beam of span 2.5 m is subjected to a uniformly distributed load and a clockwise couple as shown in figure. Draw the shear force and bending moment diagrams.

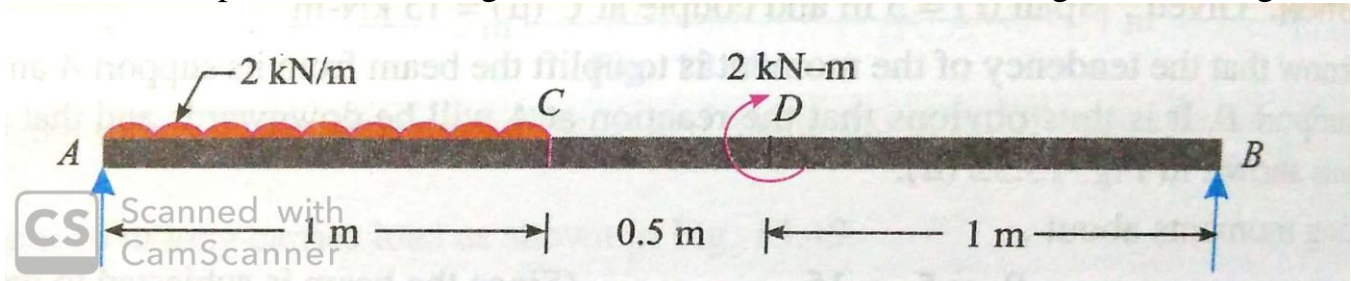

8. (a) Establish the relationship between load, shear force and bending moment.
 (b) A simply supported beam subjected to a couple M as shown in the figure. Draw the shear force and bending moment diagrams.

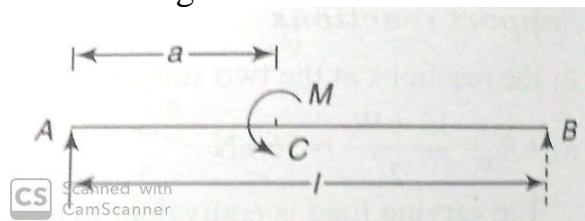

9. A simply supported beam is subjected to gradually varied load of w /unit length from left hand support to 0 at right hand support. Draw the shear force and bending moment diagrams. Also find the maximum bending moment and the point where it occurs.

10. A simply supported beam is shown in the figure. Draw the shear force and bending moment diagrams for the loads shown in figure.

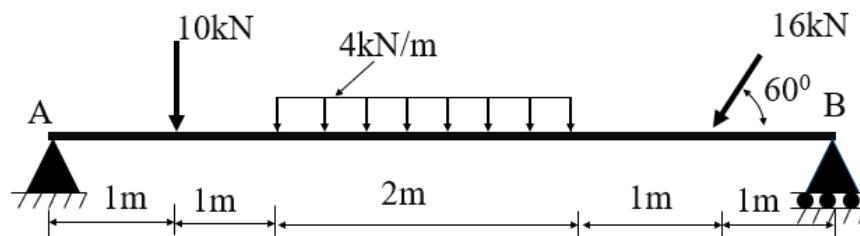

THEORY OF SIMPLE BENDING

1. List the assumptions made in deriving the flexure formula. Derive the equation $M/I = \sigma/y = E/R$.
2. A timber beam of rectangular section supports a load of 20 kN uniformly distributed over a span of 3.6 m. If depth of the beam section is twice the width and maximum stress is not to exceed 7 MPa, find the dimensions of the beam section.
3. A cast iron water pipe of 500 mm inside diameter and 20 mm thick is supported over a span of 10 m. Find the maximum stress in the pipe metal, when the pipe is running full. Take density of cast iron as 70.6 kN/m^3 and that of water as 9.8 kN/m^3 .
4. Three beams have the same length, the same allowable stress and the same bending moment. The cross-section of the beams, are a square, a rectangle with depth twice the width and a circle as shown in Figure. Find the ratios of weights of the circular and the rectangular beams with respect to the square beam.

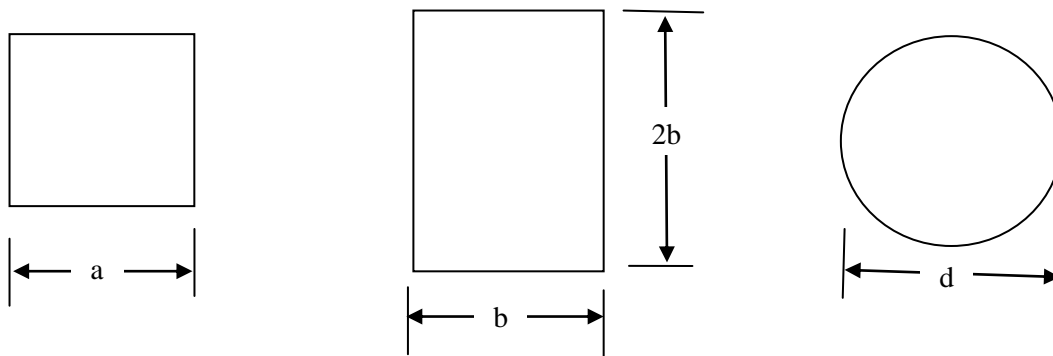

5. A circular log of timber has diameter 'D'. Find the dimensions of the strongest rectangular section to resist moment, one can cut from this log.

SHEAR STRESS DISTRIBUTION

6. (a) Derive the formula for horizontal shearing stress flexural stress.
(b) Draw the shear stress distribution for a rectangular section of width 'b' and depth 'd'.
7. Draw the shear stress distribution of triangular section of width 'b' and height 'h'. Prove that the maximum shear stress is 1.5 times the average shear stress.
8. A T-shaped cross section of a beam shown in Figure below is subjected to a vertical shear force of 100 kN. Calculate the shear stress at important points and draw shear stress diagram. Moment of inertia about the horizontal neutral axis is $113.4 \times 10^6 \text{ mm}^4$.

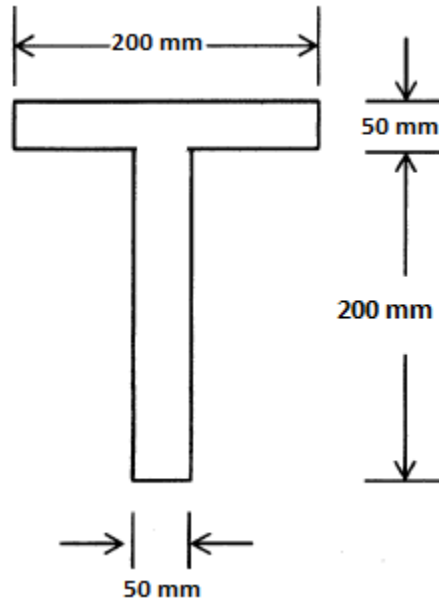

9. An I -Section of flange width 'B', overall depth 'D', width of web 'b' and depth of web 'd' is subjected to a vertical shear 'V'. draw the shear stress distribution.
10. A steel section as shown in figure below is subjected to a shear force of 20 kN. Determine the shear stress at the important points and sketch the shear distribution diagram.

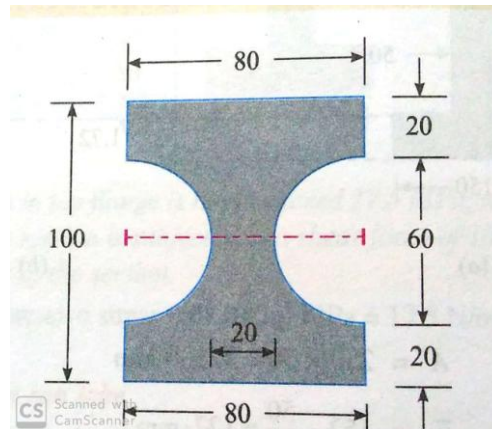

UNIT – IV DEFLECTIONS OF BEAMS

1. A timber beam of rectangular section has a span of 4.8 m and is simply supported at its ends. It is required to carry a total load of 45kN uniformly distributed over the whole span. Find the value of the breadth (b) and depth (d) of the beam, if maximum bending stress is not to exceed 7 Mpa and maximum deflection is limited to 9.5 mm. Take E for the timber as 10.5 GPa.

2. A horizontal steel girder having uniform cross-section is 14 m long and is simply supported at its ends. It carries two concentrated loads as shown in figure below. Calculate the deflections of the beam under loads C and D. Take $E = 200 \text{ GPa}$ and $I = 160 \times 10^6 \text{ mm}^4$.

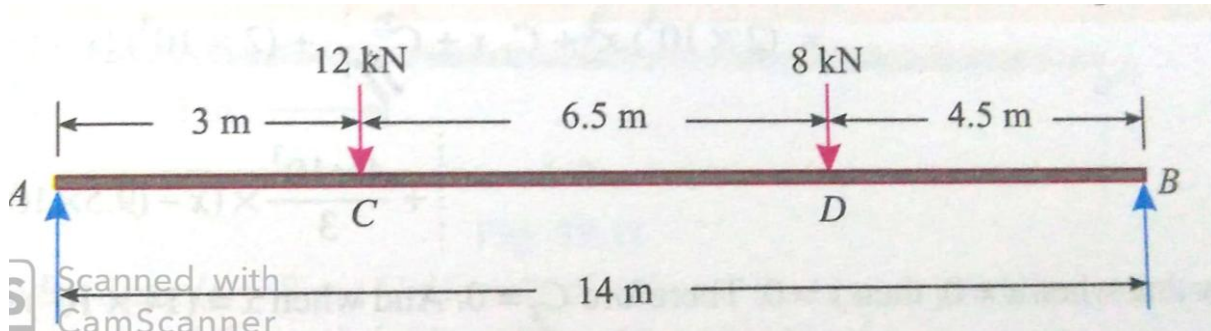

3. Find the deflection at C in the beam loaded as shown in figure below. Take $EI = 10000 \text{ kN-m}^2$.

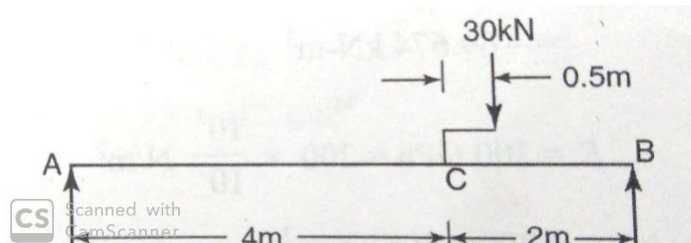

4. determine the deflection under the loads in the beam shown in figure. Take flexural rigidity as EI throughout.

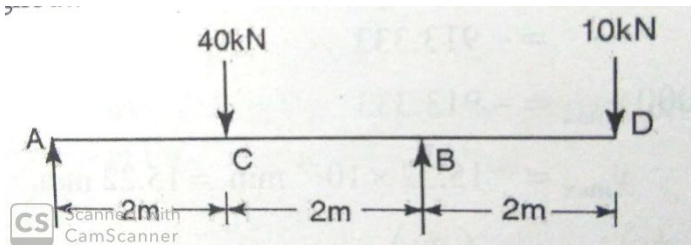

5. A beam AB of span 8 m is simply supported at the ends A and B and is loaded as shown in Figure. If $E = 200 \times 10^6 \text{ kN/m}^2$ and $I = 120 \times 10^6 \text{ m}^4$ determine: (i) Deflection at the mid span (ii) Maximum deflection (iii) Slope at the ends A.

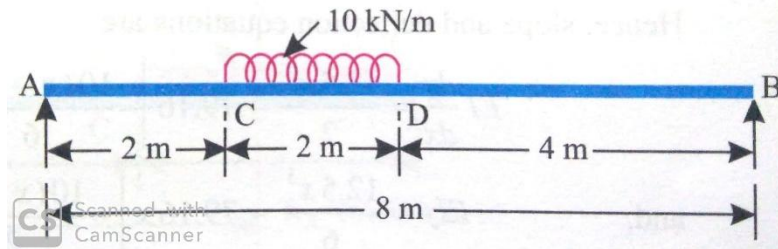

6. A simply supported beam is carrying a load 'W' at the centre. Calculate the slopes at its ends and the central deflection, using conjugate beam method.
7. A cantilever of length 6 m carries a uniformly distributed load of 10 kN/m over the whole length. If $E = 200 \times 10^6 \text{ kN/m}^2$ and $I = 30 \times 10^{-5} \text{ m}^4$, determine the following, using conjugate beam method:
 - (i) Slope at the free end
 - (ii) Deflection at the free end
8. Derive the expression for slope and deflection of a cantilever beam carrying a point load at the free end by Moment Area method.
9. Derive the equation $M = EI \frac{d^2y}{dx^2}$.
10. A simply supported beam is subjected to uniformly distributed load w /unit length completely over a span 'l'. Using Moment Area method find the maximum slope and deflection.

UNIT – V COLUMNS

1. a) What are the assumptions made in Euler's theory?
b) Find the ratio of buckling strength of a solid column to that of a hollow column of the same material and having the same cross-sectional area. The internal diameter of the hollow column is half of its external diameter. Both the columns are hinged and the same length.
2. Compare the Euler crippling loads of two columns-one of solid circular section and the second of hollow circular section of internal diameter 70% of the external diameter if they are of the same material, same length, same area, and same end conditions.
3. a) Derive the equation of Euler's crippling load on a column when both ends are hinged.
b) An angular section 240 x 120 x 20 mm is used as 6 m long column with both ends are fixed. What is the crippling load for the column? Take $E = 210 \text{ GPa}$
4. Two steel struts have the same cross-sectional areas. One is a solid and the other is a hollow with internal diameter three-fourth of the external diameter. Compare the ratio of the strength of the solid steel strut to that of the hollow one.
5. A Built-Up column consisting of 150 mm x 100 mm R.S.J with 20 mm x 12 mm riveted in each plane as shown in figure given below. Calculate the safe load of the column carry of 4 m long having one end fixed and the other hinged with a factor of safety 3.5. Take the properties of the joist: area = 2167 mm², $I_{XX} = 8.39 \times 10^6 \text{ mm}^4$, $I_{YY} = 0.945 \times 10^6 \text{ mm}^4$ and $E = 2 \times 10^5 \text{ N/mm}^2$.

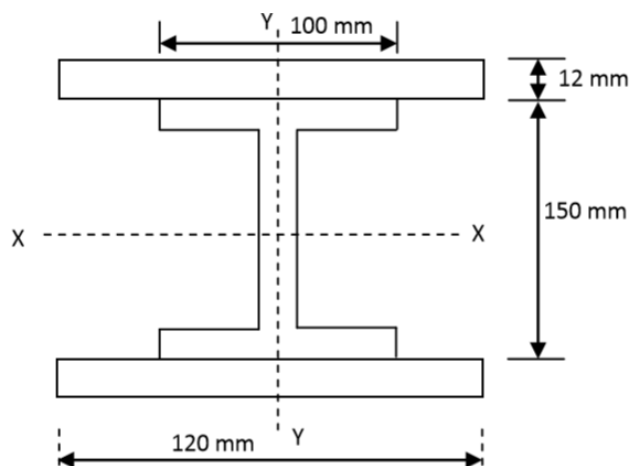

6. A rectangular column of wood, 3 m long, carries a load of 300 kN. Determine whether or not a section of size 200 mm x 150 mm will be able to carry this load if a factor of safety of 3 is to be used, assuming Euler's formula is applicable. $E = 12.5 \text{ GPa}$ and the permissible stress is 12 MPa. If this section will not be able to carry this load, design a square section to do so.

7. A built up section has an overall depth of 400 mm, width of flanges 50 mm and web thickness 30 mm. It is used as a beam with simply supported ends and it deflects by 10 mm when subjected to a load of 40 kN/m length. Find the safe load if this I-section is used as a column with both ends hinged. Use Euler's formula. Assume a factor of safety 1.75 and take $E = 2 \times 10^5 \text{ N/mm}^2$.
8. A slender pin ended aluminum column 1.8 m long and of circular cross -section is to have an outside diameter of 50 mm. calculate the necessary internal diameter to prevent failure by buckling if the actual load applied is 13.6 kN and the critical load applied is twice the actual load. Take E for aluminum as 70 GN/m^2 .
9. A 2m long pin ended column of square cross-section is to be made of wood. Assuming $E = 12 \text{ GPa}$ and allowable stress being limited to 12 MPa, determine the size of the column to support the following loads safely. (i) 95 kN (ii) 20 kN. Use factor of safety of 3 and Euler's crippling load for buckling.
10. A T-section 150 mm x 120 mm x 20 mm is used as a strut of 4 m long with hinged at its both ends. Calculate the crippling load, if Young's modulus for the material be 200 GPa.

Prepared by: C. Siva Kumar Prasad